

Documentation

Dial-Air™ Regulator - Type MANO R ... -



1. Direction

1. Direction	1
2. Caution	1
3. Installation	1
4. Maintenance	1
5. Lubrication of Dial-Air™ regulators	2
6. Setting pressure stops	2
7. Technical specifications	3
8. Dimensions and flow rate	3

2. Caution

Except as otherwise specified by the manufacturer, this product is specifically designed for compressed air service, and use with any other fluid (liquid or gas) is a misapplication. For example, use with or injection of certain hazardous liquids or gases in the system (such as alcohol or liquid petroleum gas) could be harmful to the unit or result in a combustible condition or hazardous external leakage. Manufacturer's warranties are void in the event of misapplication, and manufacturer assumes no responsibility for any resulting loss. Before using with fluids other than air for non-industrial applications or for life support systems, consult manufacturer for approval.

3. Installation

1. Refer to caution above.
2. Maximum inlet pressure is 300 psig (20,7 bar). Maximum operating air and ambient temperature is 175°(79,4°C).
3. Install as close as possible to where regulated air is needed.
4. Install the unit with the air flowing through the body in the direction indicated by the arrow.
5. Install the same pipe size as the pipe line in use. Avoid using fittings, couplings, etc., that restrict the airflow, unless maximum flow is not needed.
6. Regulator may be installed in any position. (See page 2 for details on how to adjust regulator.)
7. A pressure gauge is not required; however, a gauge may be attached to one of the 1/4" NPT female cross ports. These ports may also be used as regulated outlets; otherwise, plug both cross ports.
8. Panel mounting requires a 2 11/16" (69 mm) diameter hole. Units may be mounted on panel up to 1 1/4" (32 mm) thick. Before mounting the unit, remove the adjustment knob. Replace adjustment knob after regulator is mounted.

4. Maintenance

1. Occasionally remove bottom plug and clean plug, body valve seat and main valve. Relubricate o-ring seal with Magnalube-G® whenever regulator is cleaned. (See page 2 for lubrication instructions.)
2. **To disassemble:** Shut off air to regulator and vent air line on both sides of regulator. Remove lock knob, adjustment knob, and retaining ring. Leave dial screw in position. It is not necessary to remove this screw to service unit. Lift bonnet assembly out of the body and remove pistons, support washer, and Belleville springs. Remove the bottom plug and pull out the main valve and pilot valve. (See items 4 and 5 below.)
3. **To assemble:** Relubricate all seals and sealing surfaces with Magnalube-G®. Assemble main valve, pilot valve spring, pilot valve, main valve spring, and bottom plug. Lay bottom piston, with flat surface down, on assembly table.

Slip upper piston assembly on bottom piston. Add support washer and two Belleville springs with inside diameters contacting. Place spring and needle/o-ring assembly into top of upper piston. Place bonnet assembly on assembled pistons and press down firmly. Place o-ring in body. Place assembled bonnet and pistons in body and install retaining ring.

Caution: Ensure retaining ring is fully locked into retaining groove in Body.

Install the adjustment knob and then the lock knob.

4. **If unit will not regulate to pressure needed, or if pressure drop becomes excessive:** Remove bottom plug, main valve, and pilot valve. Clean and check seals and valve seats for wear or damage. Relubricate seals with Magnalube-G®.
5. **If unit leaks under adjustment knob:** The cause may be dirty or worn main valve seat. Install Repair Kit. As small, constant bleed of up to 5 SCFM is normal.

Install Belleville springs like this...

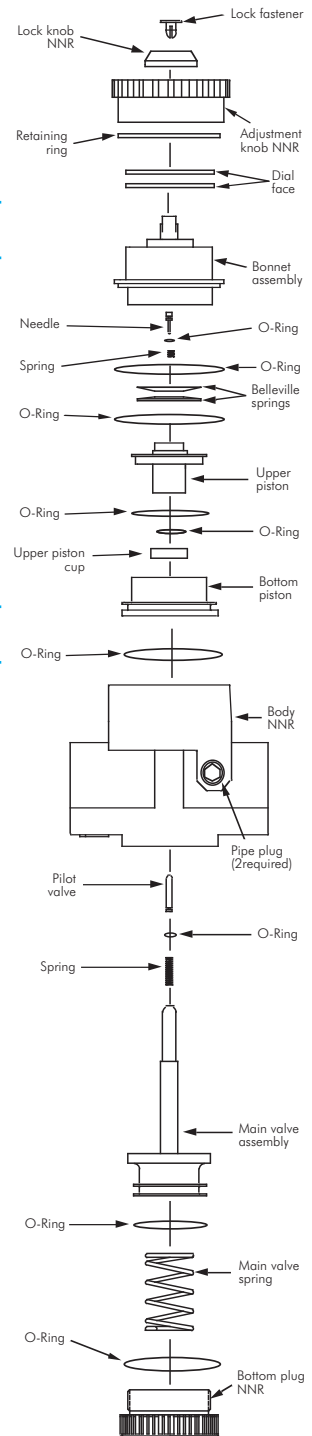

NNR = not normally replaced

5. Lubrication of Dial-Air™ regulators

The factory packs all moving seals with a heavy lubricating grease. Under normal conditions this will last through millions of cycles. However, under conditions of wet air, unusual high flows, or light oil from a lubricator somewhere in the circuit moisture can get into the Dial-Air™ regulator and the original lubrication can be washed out.

Proper lubrication in our Dial-Air™ series regulators is absolutely essential.

Symptoms of a dry regulator:

1. Excessive leaking through the relief vent.
2. Loss of calibration.
3. Regulator cannot attain high secondary pressures.
4. Erratic secondary pressures.

Remedy:

Disassemble regulator and lubricate indicated seals with Magnalube-G®.

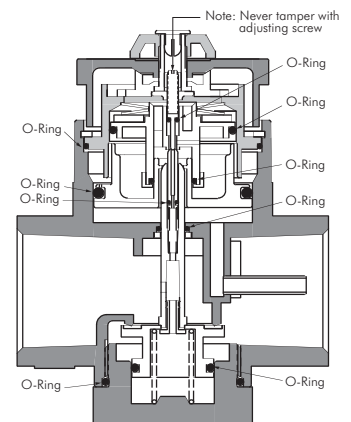

6. Setting pressure stops

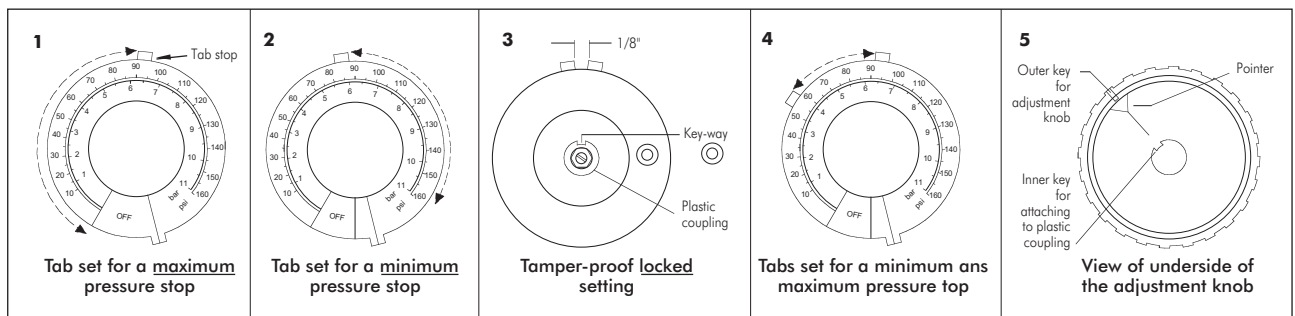

1. **To set adjustment to a maximum pressure stop**, an adjustment tab is provided so that regulator adjustment cannot be turned past a preset maximum pressure. To preset this tab, remove the clear plastic knob by first taking off the white plastic lock knob. Loosen dial screw and rotate tab stop to the desired pressure limit. Set groove of the white plastic coupling anywhere between zero and the tab stop. Line up the inner key on the clear plastic adjustment knob with the groove and drop in place. Outer key on the adjustment knob must now be to the left of the tab stop.
2. **To set adjustment to a minimum pressure stop**, repeat the process above, but set the groove of the white plastic coupling anywhere between the pressure desired and the maximum pressure number, 160. When the adjustment knob is replaced, its outer key should now be to the right of the tab stop. Adjustment can now only be made between tab and maximum pressure.
3. **Adjustment can be fixed at a set pressure** by purchasing Tamper-Proof Kit. This is just an additional tab stop ring. Remove the dial screw and the white dial face, place the additional ring on top of the original ring and replace the white dial face and dial screw. Set one of the tab stops on one side of the pressure desired; set the other to the opposite side of the pressure figure, as shown. Leave approximately 1/8" between the stops, and tighten dial screw. Set the groove of white plastic coupling in line with desired pressure number, and replace adjustment knob so that key on inside of the outer edge of the clear plastic knob is located between the two tabs. Replace lock knob. The locked adjustment is now also tamper proof because the operator would have to remove both knobs to change it.
4. **To locate tabs so that adjustment can be made only between a predetermined minimum and maximum**, follow the same procedure above, except spread the tabs further apart, to the minimum pressures desired, and locate outer key of adjustment knob between the two tabs.

Warning: If dial screw and washer have been removed, do not rotate keyway of plastic coupling through the "off" position on the scale of the dial face. This can offset the calibration so that the reading on the dial would not match a pressure gauge.

7. Technical specifications

Manometerregler

bis 24 000 l/min

Ausführung: Druckregler rücksteuerbar (mit Sekundärentlüftung)

Temperaturbereich: 0°C bis max. +65°C

Eingangsdruck: max. 21 bar

Eigenluftverbrauch: max. 1,4 l/min

Medien: geölte und ungeölte Druckluft, ungiftige und nicht brennbare Gase

- Vorteile:**
- Druckeinstellung erfolgt über einen leicht drehbaren, großen Einstellknopf.
 - Druckeinstellung ist von Skala unter durchsichtigem Einstellknopf abzulesen.
 - Abdeckung des gesamten Einstellbereichs durch eine Verdrehung von 270°.
 - Übernimmt die Funktion eines 3/2-Wege-Absperrventils, eines Druckreglers und die eines Manometers in einem Gerät.
 - Ideal für den Schalttafeleinbau.

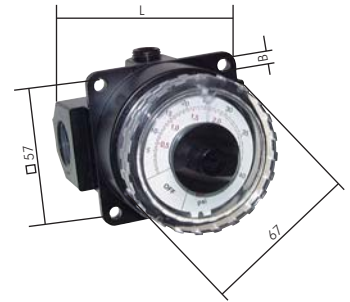

Typ	Gewinde	L	B	Durchfluss	Druckregelbereich
MANO R 14 3	G 1/4"	81	5,5	3000 l/min	0 - 3 bar
MANO R 14 11	G 1/4"	81	5,5	3000 l/min	0 - 11 bar
MANO R 12 3	G 1/2"	81	5,5	5000 l/min	0 - 3 bar
MANO R 12 11	G 1/2"	81	5,5	5000 l/min	0 - 11 bar
MANO R 34 3	G 3/4"	109	5,5	8000 l/min	0 - 3 bar
MANO R 34 11	G 3/4"	109	5,5	8000 l/min	0 - 11 bar
MANO R 10 3	G 1"	109	5,5	9000 l/min	0 - 3 bar
MANO R 10 11	G 1"	109	5,5	9000 l/min	0 - 11 bar
MANO R 20 3	G 2"	135	---	24000 l/min	0 - 3 bar
MANO R 20 11	G 2"	135	---	24000 l/min	0 - 11 bar

8. Dimensions and flow rate

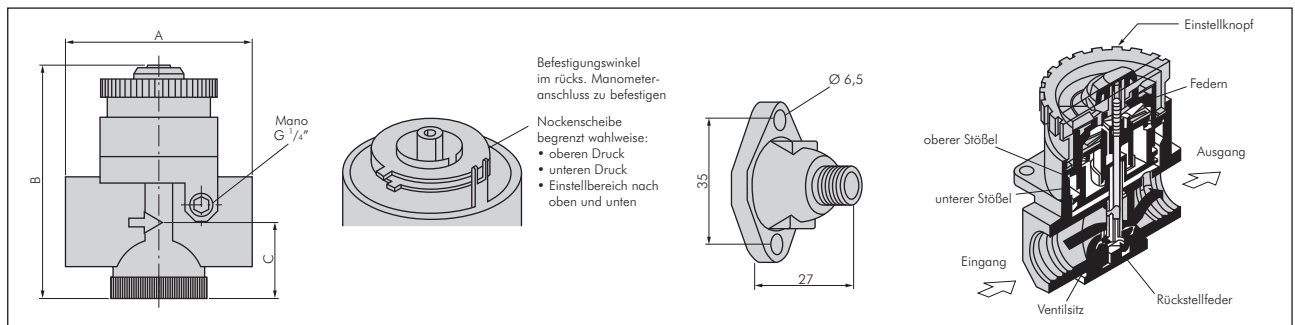

Typ	A	B	C	Kv-Wert	Volumenstrom m ³ /h	Volumenstrom l/min	Anschlussgewinde
MANO R 14	81	104	24	2,5	180	3000	G 1/4"
MANO R 12	81	104	43	4,2	300	5000	G 1/2"
MANO R 34	109	132	43	6,8	480	8000	G 3/4"
MANO R 10	109	132	43	7,6	540	9000	G 1"
MANO R 20	135	173	71	37,1	1440	44000	G 2"

